

DAY 2 FRIDAY, 24 JANUARY 2025

SHOWDAILY™

The Daily News of IMTEX 2025

Organiser



Indian Machine Tool
Manufacturers' Association



International Machine Tool &
Manufacturing Technology Exhibition

Concurrent Shows



International Exhibition of Cutting Tools, Tooling Systems,
Machine Tool Accessories, Measuring & QC/CIM



International Exhibition on
Digital Manufacturing Technology

23 - 29 January 2025 · BIEC, Bengaluru



Scaling new heights
in manufacturing



Asia's Leading Fixture Builder



Winner of CII Industrial
Innovation Award 2020

Trusted By The World's Best Companies

For over 50 years Forms and Gears has been designing and manufacturing fixtures for the world's leading companies, in 10 countries across the globe.

RV Forms & Gears LLP

MF 11, SIDCO Industrial Estate, Guindy,
Chennai - 600 032, Tamilnadu, India
Call +91 77570 53326 or email us on
marketing@rvformsandgears.com

www.rvformsandgears.com





Asia's Leading Fixture Builder



Winner of CII Industrial Innovation Award 2020



Trusted By The World's Best Companies
For over 50 years Forms and Gears has been designing and manufacturing fixtures for the world's leading companies, in 10 countries across the globe.

RV Forms & Gears LLP
MF 11, SIDCO Industrial Estate, Guindy,
Chennai - 600 032, Tamilnadu, India
Call +91 77570 53326 or email us on
marketing@rvformsandgears.com
www.rvformsandgears.com



AUTOMATED SOLUTIONS FOR METAL CUTTING

MW80HGT

Twin Spindle Twin Gantry Chucker

MW120EX

Twin Spindle CNC Chucker

MT100/T3

Ultimate Multi-Tasking
Twin Spindle Machine

MWR120

All New Twin Spindle
Turn-Mill Centre with Y Axis

VISIT US AT
**HALL 5
STALL B105**

Bangalore | Chennai
Mumbai | New Delhi | Pune

AND THE SHOW IS DECLARED OPEN

IMTEX 2025: Advancing Innovation and Machining Frontiers

IMTEX 2025 & Tooltech 2025 has opened its doors with unparalleled grandeur, setting a new benchmark in scale and scope. The show commenced on a high note, attracting visitors from a wide range of industries eager to explore technological advancements and groundbreaking innovations. With exhibitors showcasing refined machining solutions and next-generation technologies, the event promises to redefine the future of manufacturing.



IMTEX & Tooltech 2025, organized by Indian Machine Tool Manufacturers' Association (IMTMA), kickstarted on a high note yesterday at Bangalore International Exhibition Centre (BIEC), Bangalore with visitors pouring in from a wide variety of sectors. This edition of the world-class machine tools exhibition holds a special significance since it is grander in scale than all its predecessors, spanning 90,000 sq mt across eight exhibition halls.

A Confluence of Industry Titans
The event witnessed the presence of esteemed dignitaries, including Shri HD Kumaraswamy, Hon'ble Minister for Heavy Industries and Steel, Government of India; Dr MB Patil, Hon'ble Minister for Large & Medium Industries and Infrastructure Development, Government of Karnataka; Laxmesh BH, Vice President & Head, Aerospace & Systems Business, Larsen & Toubro Ltd; and Prashanth Doreswamy, President & CEO, Conti-

mental Automotive (India) Pvt Ltd, who lighted the inaugural lamp. Jamskyd N Godrej, Chairman - Exhibitions, IMTMA; Rajendra S Rajamane, President, IMTMA; Mohini Kelkar, Vice President, IMTMA; and Jibak Dasgupta, Director General & CEO, IMTMA, also shared the dais at the inauguration. Speaking at the event as the Chief Guest, Shri Kumaraswamy said that a strong machine tool industry is essential for a robust manu-

To be continued on 4 ▶

ECOCLEAN
technology that inspires

Join us at
**Hall 4A
Stall C118**

23 - 29 January | IMTEX 2025

The Wait is Over.
Meet
EcoCvertex
Elevating Standards,
Maximizing Efficiency



Explore the compact, versatile, and future-ready industrial components cleaning technology!

+91 902 826 1666
info.india@ecoclean-group.net



Transforming the future of machine tool manufacturing

Accelerate sustainable, digital, future-proof transformation now!

Visit us at Hall 5, Booth B112

facturing sector. He shared that Karnataka generates around 50 percent of India's machine tools and is often referred to as the machine tool capital of India. The Guest of Honour, Dr Patil acknowledged the machine tool sector as the cornerstone of manufacturing. He opined that the Indian Machine Tool industry has grown significantly over the years and metal cutting is an important segment in this growth. Laxmesh BH, in his address, emphasized that IMTEX is a confluence of great ideas and minds and

Pavilion provides an opportunity for Indian academic and R&D institutions to showcase their research capabilities and make it available for commercial use. The Auto Components Industry Transformation Summit (on January 26, 2025), organized by IMTMA and the Automotive Component Manufacturers Association of India (ACMA), is expected to further strengthen the ties between the Machine Tool and Auto Component industries.

Awards & Recognition



Source: IMTMA

driving the manufacturing growth of India. Doreswamy echoed his sentiment and hailed the Machine Tool industry as a key contributor to several industries including the Auto sector. He highlighted that around 55 percent of the machine tools produced in India is consumed by the Auto industry. In his address, Rajamane said that India ranks 9th in Production and 6th in Consumption, globally, as per estimates from Gardner Intelligence's World Machine Tool Survey 2023. The Machine Tool industry production is estimated to have increased by around 10 percent year-on-year, reaching INR 13,571 crore, which is around (US\$ 1.6 billion). He noted that IMTEX 2025 is convening machine tool user industry leaders, policymakers and innovators from around the world to find actionable solutions for the future.

IMTMA - Cooper Award for Outstanding Supply Chain Unit in Memory of Sir D.B. Cooper: The prestigious IMTMA-Cooper Award for Outstanding Supply Chain Unit, instituted in memory of Sir D.B. Cooper has been conferred upon Sphoorti Machine Tools for the year 2025. The company is a recognized leader among supply chain companies in the Indian machine tool sector. The award has been established in cherished memory of the illustrious Sir D.B. Cooper, whose visionary leadership and pioneering efforts shaped the trajectory of Indian Machine Tool Manufacturers' Association (IMTMA). It serves as an accolade to recognize the significant contributions of supply chain units to the Indian Machine Tool industry.

IMTMA - Premier Outstanding Entrepreneur Award In Memory Of Vinod Doshi Citation



Source: IMTMA

A Comprehensive Display of Innovations

Apart from a display of products and solutions, various programs have been lined up at IMTEX 2025. 'International Seminar on Machining Technologies' from January 24-25, 2025 will have global experts sharing insights into emerging trends and the best practices in metal cutting. The 'i2' Academia

IMTMA - Premier Outstanding Entrepreneur Award In Memory Of Vinod Doshi Citation for the year 2025 has been conferred upon Vikram Salunke of Accurate Group, a metrology solutions company. The entrepreneurial skills of Vikram Salunke have helped the Group expand its horizon beyond geographical boundaries, develop path-breaking technologies, and earn a global reputation.

50 ANCA YEARS OF INNOVATION

UNLOCK PRECISION IN ELECTRONICS MANUFACTURING WITH ANCA CNC MACHINES



Download a free whitepaper on the latest trends, opportunities, and strategies shaping India's thriving electronics sector



Visit us at IMTEX 2025
Hall 4, Stand B110



Experience the Value in our Machines & Solutions

Hall - 5, Stall - A-108

High Precision Horizontal Turnmill Centers

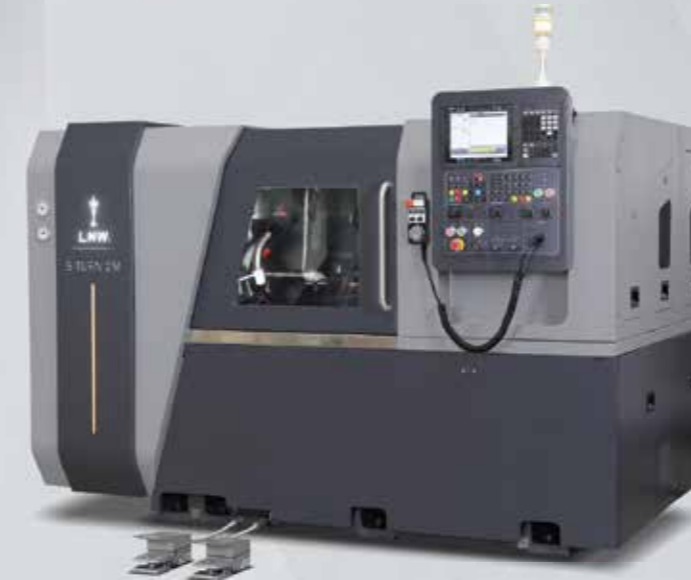

S Turn 2M Compact TMC

- Max. Turning Length - 400 mm
- Max. Turning Dia - 320 mm
- Chuck size - 200 mm
- 12 station live tool turret
- Rotary tool speed 6000 rpm
- Tool change time 0.7 sec

LR30MY L17 Large TMC

- Max. Turning Length - 1700 mm
- Max. Turning Dia - 520 mm
- A2 -15 spindle nose
- Chuck size - 533 mm
- 12 station live tool turret
- Y axis ± 60 mm



LR40TM L25 Large TMC

- Max. Turning Length - 2320 mm
- Max. Turning Dia - 550 mm
- A2 -15 spindle nose
- Chuck size - 533 mm
- 12 station live tool turret
- Rotary tool speed 4000 rpm

FOLLOW US ON :
f in x y
LMW CNC



INDIA'S FINEST RANGE OF CNC MACHINES

TURNING MILLING TURNMILL



www.lmwcnc.com

DIAMOND WIRE SAWS

Chennai Metco's Diamond Wire Saw



Chennai Metco introduces India's first diamond wire saw, a versatile sectioning system capable of cutting a wide range of materials with precision. This advanced machine is ideal for sectioning electronic parts, PCBs, and devices at desired positions while minimizing cutting damage, ensuring superior results in electronic applications. Beyond electronics, the diamond wire saw is utilized in atomic research, space exploration, and glass tube cutting, demonstrating its adaptability across various high-precision fields. Developed in collaboration with IIT Madras and the Advanced Manufacturing Technology Development Centre (AMTDC), this machine represents a significant advancement in cutting technology, meeting the diverse needs of modern industries.

Chennai Metco Pvt Ltd
www.chennai-metco.com
Hall & Stall: 1/A-101

MACHINE LAUNCH

LMW Ltd's Unveils Two New Innovations at IMTEX 2025

LMW Ltd has unveiled two groundbreaking innovations, further expanding its portfolio of advanced machines. The launch event took place yesterday at IMTEX 2025.

The LR30MYL17, a Horizontal Turnmill Center, was unveiled by Col. Sanjeev Rathore, Ex-Indian Defence, Ex-Head, Bharat Earth Movers Ltd (BEML) and Venkatesh Kulkarni, Advisor, Wipro Ltd. The high-performance machine is designed for industries, including Oil & Gas, Automobile, Defence, and Aerospace.

The machine has a turning length of 1700 mm and a diameter of 520 mm. It features an A2-15 spindle nose, a 533 mm chuck size, and a 12-station live tool turret. Its Y-axis travel of ±60 mm ensures precision for complex parts.

The LL20TL5S, a Horizontal Turning Center, was launched by Aswini Kumar, Managing Director, Autocrat Engineers. Targeting industries such as General Engineering, Pump & Valve, and Oil & Gas, the LL20TL5S offers a turning diameter of 370 mm and a length of 500 mm. It features an A2-6 spindle nose, 210 mm chuck size, and a 12-station turret with a rapid tool change time of just 0.55 seconds, ensuring high productivity.



LMW Ltd | www.lmwnc.com | Hall & Stall: 5/A-108



We care for the manufacturing community

Visit us at **Booth B103 Hall 4A**



Milling



Holemaking



Drilling

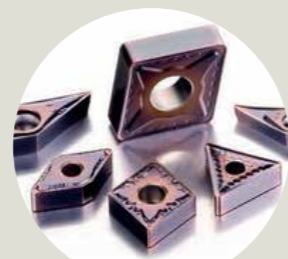

Turning



Threading

Measuring Technology



Booth #B108
Hall 3A

toolVibe®

Sensory toolholder enabling targeted optimization of processes around the machine tool, supporting increased efficiency

www.rego-fix.com



INDUSTRIAL PARTS CLEANING SOLUTIONS

Clean Matters



Ecoclean Machines Pvt Ltd views IMTEX 2025 as a key platform to demonstrate its technological leadership in industrial parts cleaning solutions. "It enables us to engage directly with customers, understand their evolving needs, and highlight how our advanced cleaning systems are tailored to address these challenges effectively," says Manoj Velhal, Sales Director, Ecoclean Machines.

Innovations at IMTEX 25

At IMTEX 2025, Ecoclean is prominently showcasing a particle scanner and two of its advanced

cleaning solutions. EcoCvertex, an aqueous-based cleaning system, features versatile methods like spray cleaning, ultrasonic cleaning, and smart drying technologies. It offers precision and efficiency with future-ready capabilities like Hydro Pulse Vacuum Cleaning (HPVC) and Acoustic Performance Measurement (APM).

UCMCombiLine is a modular ultrasonic cleaning system ideal for manual workstations with low throughput, equipped with dual-frequency ultrasonic technology, automatic oscillation, and customizable modules.

Catering to Indian Industries

Ecoclean offers Made-in-India aqueous-based, solvent-based single chamber cleaning systems, modular ultrasonic cleaning machines, and robotic washers for a wide range of applications. "In addition to mobility, aerospace, and metalworking, these machines cater to industries demanding stringent cleanliness standards, such as ISO 16232/VDA 19 for automotive and a variety of standards from the medtech and precision optics industry," explains Velhal. Ecoclean's machines provide advanced, reliable, and eco-friendly cleaning solutions utilizing local service support for the Indian market, powered by several advanced processes—Injection Flood Washing, Spray Cleaning, Ultrasonic Cleaning, and Drying.

Adapting to the EV Transition

As the automotive industry evolves from conventional IC engines to electric vehicles (EVs), Ecoclean has



» We aim to leverage this global stage to strengthen our brand, build lasting partnerships, and redefine industrial cleaning excellence.«

Manoj Velhal
Sales Director
Ecoclean Machines Pvt Ltd

adapted its cleaning solutions to address the specific needs of EV components. Velhal asserts, "Ecoclean's systems are engineered to meet these requirements by considering factors such as production process, type of contamination, cleanliness specifications, throughput rates, and cycle times." SD

Ecoclean Machines Pvt Ltd
www.ecoclean-india.com
Hall & Stall: 4A/C-118

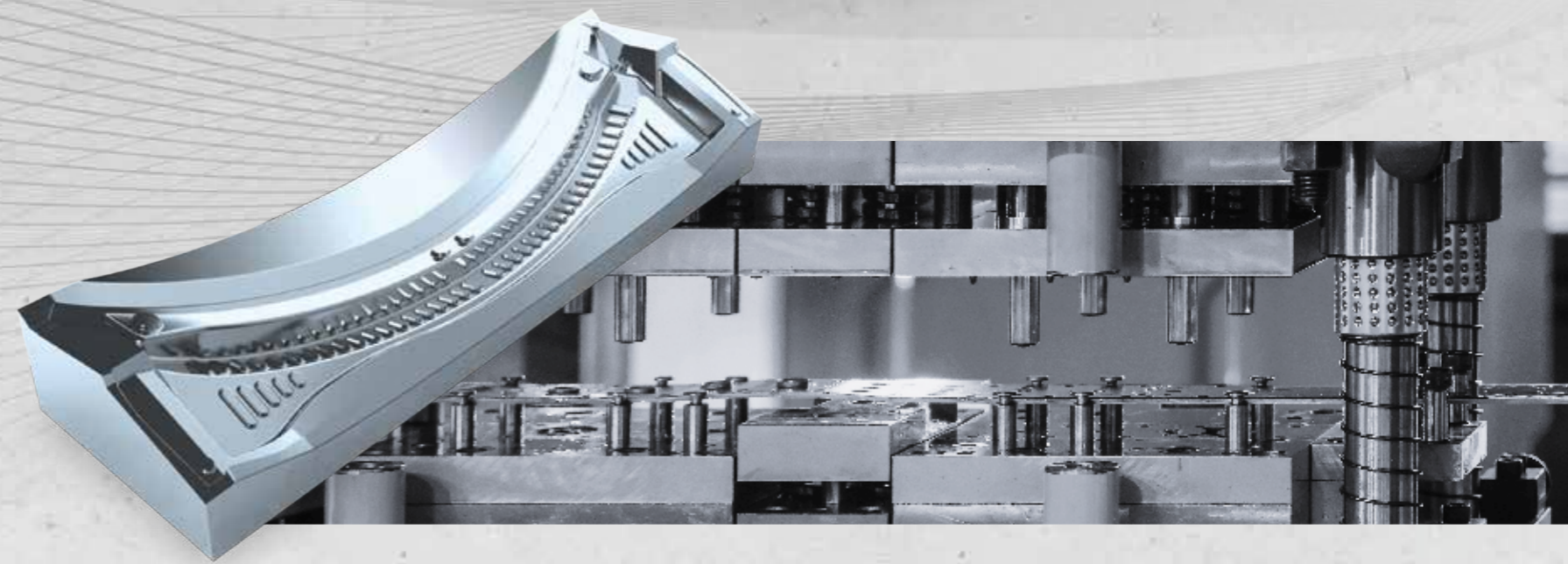

Vertical Machining Centers

VC-EZ IP SERIES

Made in India: High-performance vertical machining centers



- Powerful, high-torque spindle for higher productivity
- Largest table and machining area in its class
- Designed for stable, high accuracy machining
- MAZATROL SmoothEz: CNC system for unsurpassed usability and high productivity

Mazak

Yamazaki Mazak India Pvt. Ltd.

PUNE TECHNOLOGY CENTER

115, Pune Nagar Road, Sanaswadi, Pune. 412208.

www.mazak.com

#High5

5-AXIS UNIVERSAL MACHINING CENTERS

For the highest accuracy, dynamics & process reliability!



WANT TO KNOW MORE?



Contact us and visit us at
IMTEX, (BIEC) Bengaluru
Jan 23-29, 2025 • Hall 4 | C116



www.grobgroup.com

MACHINE LAUNCH

Jyoti's Tachyon Beta Drill Tap Center



Jyoti CNC Automation Ltd
www.jyoti.co.in
Hall & Stall: 5/A-122

The Tachyon Beta sets a new standard in the world of Drill Tap Centers, combining cutting-edge linear motor technology with exceptional speed and accuracy. It outperforms previous models by a significant margin, making it one of the fastest machines in its class.

Key Features:

- **Spindle Speed:** High-speed spindle rotation at 42,000 rpm, enhancing performance and efficiency.
- **Rapid Traverse Rate:** Achieves an impressive 120 m/min in axis rapid rates, ensuring rapid movement across the workspace.
- **Axis Acceleration:** Accelerates up to 2g, providing optimal responsiveness and precision.
- **Tool Storage Capacity:** 40 automatic tool changer pockets offer greater flexibility and fewer tool changes.
- **Compact Design:** Being the most compact simultaneous 5-axis machine, it maximizes space without compromising on performance.
- **Tool Change Time:** The tool-to-tool change time is just 0.7 seconds, boosting productivity with minimal downtime.

Designed to excel in both speed and precision, the Tachyon Beta is the ideal solution for high-performance machining needs. **SD**

CUTTING TOOLS & HARD MATERIAL SOLUTIONS

CERATIZIT Group Showcases Cutting-Edge Solutions at IMTEX 2025



at IMTEX 2025. The ceremonial inauguration at Stall B110, Hall 3A was led by Melissa Albeck, Member of the Executive Board, accompanied by Andreas Fritz, President, CERATIZIT Asia Pacific, and Anil Kumar, Managing Director, CERATIZIT India.

Speaking at the inauguration, Albeck emphasized the company's sustainability mission, "Sustainability is not just a goal—it's our mission. It lies at the heart of our innovations, driving us to develop solutions that deliver exceptional performance while

minimizing environmental impact through energy-efficient processes and a circular approach to raw materials."

"With tools designed to lower energy consumption and enhance operational efficiency, we're leading the way in creating a more sustainable future for the world and generations to come," added Fritz. "We are thrilled to once again participate in IMTEX and showcase CERATIZIT's cutting-edge solutions. Our preparation reflects customer-centricity along with our commitment to innovation and sustainability to meet evolving industry needs," said Kumar. **SD**

CERATIZIT India Pvt Ltd
www.ceratizit.com
Hall & Stall: 3A/B-110

CERATIZIT, a world-renowned high-technology engineering group specializing in cutting tools and hard material solutions, inaugurated its participation at IMTEX 2025 yesterday

Enhancing Manufacturing Industry Competitiveness

Upskilling Young Engineers and Industry professionals

200+ Focused Technical Training Programmes on

Design

Productivity

Metal Forming

CNC Machining

Quality

Automation

Maintenance

Emerging Technologies

Technology Centres

Bengaluru

Pune

For further details, please contact: Ph : +91 9886331231 ; E - Mail : training@imtma.in

www.imtmatraining.com

www.imtmaelearn.in

High Performance

GEAR HOBBING MACHINES

Visit Us For **LIVE** Demonstrations

Scan this code or Log on to nimblemachines.co.in

Contact
+91 9742224391
sales@nimblemachines.co.in
www.nimblemachines.co.in

Witness NEW FEATURES

7 Axis CNC Controlled

Direct Drive technology in spindle and work table

High precision Electronic Gearbox (EGB)

Software suitable for Spur, Helical, Sprocket and Spindle

Available with automation and remote diagnostic features

DIRECT DRIVE MOTORS

For Advanced Manufacturing

Orion

600V DC Torque motors

Vaayu

175V DC Torque motors

Phoenix

48V DC Torque motors

Topaz

12V DC Torque motors

Opal

24V DC Torque motors

Please visit us at **Stall No. A102, Hall No. H1A**

Ministry of Heavy Industries, Govt. of India & Bureau of Indian Standards, Govt. of India
“Machinery and Electrical Equipment Safety (Omnibus Technical Regulation) Order, 2024”

Mandatory “OTR Order 2024” Registration by Every Indian & Overseas Manufacturer of metal-cutting machines, accessories, aggregates, attachments and components of machine tools

NO sale permitted in India, without “OTR Order 2024” registration, from September 2025

MHI, BIS and IMTMA are Organising ‘Awareness Session for Indian and Global Machine Tool Industry @ IMTEX 2025’

1500 – 1730 hours | Monday, 27 January 2025
‘Jacaranda’ Hall in “Conference Centre”, BIEC (No Charges for Participation | MUST ATTEND)

INTERNATIONAL SEMINAR ON MACHINING TECHNOLOGIES™
 24 - 25 January 2025, BIEC, Bengaluru

DAY 1	Date: January 24, 2025 Time: 2 pm – 5.20 pm Venue: Conference Centre
DAY 2	Date: January 25, 2025 Time: 10 am – 1.55 pm Venue: Conference Centre



SEMINAR

ISMT 2025 to Spotlight Machining Technologies Trends

Organized by Indian Machine Tool Manufacturers’ Association (IMTMA), International Seminar on Machining Technologies (ISMT) 2025, is set to take place from January 24 – 25, 2025, during the IMTEX 2025 exhibition, at BIEC, Bangalore. The flagship event is dedicated to bringing the global manufacturing community together and highlighting evolving trends in machining technologies. To be held simultaneously in Gulmohar and Jacaranda Halls, Conference Centre, the seminar with its blend of insightful keynotes, technical sessions, and panel discussions, promises valuable perspectives on the challenges and opportunities in the ever-evolving manufacturing landscape. **SD**



Rajamane & Hegde Services Pvt Ltd



2SP2 Motorspindles



2SP2 the new middle-class standard

The new 2SP2 asynchronous milling spindle series is characterized by robustness and performance. Its compact dimensions meet the necessary requirements to keep the space requirement in the machine as low as possible. The option with or without external cooling jacket offers the machine builder flexibility in designing the connection of the spindle to the Z-slide.

Here, the new spindle series with an outer diameter of 170 mm already achieves a nominal torque of 45 Nm. For applications requiring more spindle torque, a variant with an outer diameter of 210 mm is available.

The spindle has been designed with a slim diameter and open cooling jacket but is also optionally available with a closed cooling jacket.

The robust bearing system ensures speeds of up to 20,000 rpm with lifetime grease lubrication. For speeds of up to 24,000 rpm, a version with air-oil lubricated bearings is also available. The specially developed asynchronous motor is equipped with loss-optimized profile rods to keep the rotor losses as low as possible. In this way, the spindle ensures low heat-up and reduced growth at the tool interface, even at maximum speeds.

For more information, please ask for spindle catalogue.

India’s only authorised service partner for Weiss spindles

Launching STM i-CON
 IoT Integration for Productivity and Precision in Manufacturing



EXPERIENCE REAL-TIME MONITORING FOR SMARTER MANUFACTURING



Smarter Machines Manufacture Faster

IoT-Integrated Machines – for Live Experience

S&T MACHINERY (P) LTD.

+91-422-2590810 | +91 99725 00090
 info@stmnc.com | www.stmnc.com

DISCOVER THE MEANING OF VALUE



S&T GROUP
 SINCE 1996



Visit Our Stall
HALL: 1A
STALL NO: B101

LIQUID TOOL

Seeking Sustainable Solutions



L-R: Ajit Gugale, President, ZF Steering Gear (India) Ltd; Dmitry Bernadiner, Chief Officer, ZF Steering Gear (India) Ltd; Prashant Godha, Sales Director, Automotive, Blaser Swisslube Solutions Pvt Ltd and Anand Kumar, Director, Proserv Tools Pvt Ltd

ZF Steering Gear (India) Ltd is a pioneer in the manufacturing and supply of Ball and Nut Integral Hydraulic Power Steering and Worm and Roller Mechanical Steering Systems in India. The company's manufacturing plants are located near Pune, Maharashtra, and at Pithampur, Madhya

Pradesh. It utilizes state-of-the-art technology to design and manufacture power and mechanical steering systems tailored to customers' needs. To meet the growing demands of the automotive market, the company continuously expands its product base and diversifies into new product lines.

Company Name: ZF Steering Gear (India) Ltd
Industry: Automotive
Production: Ball and Nut Integral Hydraulic Power & Worm and Roller Mechanical Steering Systems
Application: Machining and Grinding
Material: Steel and S.G. Iron

Objective: ZF Steering Gear (India) Ltd required a robust coolant system with a focus on cost optimization.

Solution: Blaser Swisslube Solutions and Business Partner Proserv Tools (Business Partner) collaborated with ZF Steering Gear (India). Leveraging high-performance water miscible and neat oil products, along with application engineering support and tailored services, they provided innovative solutions for delivering enhanced tool life, improved productivity, and prompt service.



ZF Steering Gear Ensures Safety & Comfort

The machine shop employs sophisticated, world-class manufacturing processes to produce steering components. Its technology features state-of-the-art machines sourced from Germany and Japan, ensuring exceptional accuracy to meet customer demands and maintain a competitive edge. The shop specializes in machining both soft and hard components with tolerances within micrometres, delivering high process reliability.

Robust Collaborative Efforts

In 2012, ZF Steering Gear (India) was seeking a reliable coolant partner to enhance productivity, tool life, and sump life. Following extensive research and consistent results with Blaser Swisslube Solutions, ZF Steering Gear (India) in 2014 transitioned from a stand-alone system to a centralized system. Prashant Godha, Sales Director, Automotive Segment, Blaser Swisslube, proposed a systematic handling and care plan to maintain the emulsion health.

The centralized system achieved a sump life of 6 years, surpassing the committed 5-year sump life. In 2020, the system was refilled with a new solution from Blaser and this time, the central system is expected to achieve an even longer sump life. This was made possible with the collaborative efforts and strong teamwork between ZF Steering Gear (India), Blaser Swisslube, and Proserv Tools (Business Partner).

Teams from Blaser Swisslube and Proserv Tools have been working continuously over the past 12 years with ZF Steering Gear (India), adding value in machining and grinding applications. Leveraging high-performance water miscible and neat oil products, along with application engineering support and tailored services, they have provided innovative solutions for enhanced tool life, improved productivity, and prompt service. Solutions from Blaser Swisslube are not just high-performance but also offer excellent compatibility with both materials and machines. Environmentally friendly and safe for users, they are free from harmful substances such as boron and formaldehyde, etc. The fluid helps keep both workpieces and machines clean and runs smooth even in high-pressure systems.



» Customers like ZF do not just want a cutting fluid but are also looking for a competent and dependable partner to help organize and optimize their machine processes. With our committed team, we provide this partnership.«

Punit Gupta
Managing Director
Blaser Swisslube Solutions Pvt Ltd

Going Green

Zero disposal in six years is a significant contribution to the environment. It has prevented the disposal of lakhs of liter of coolant, ensuring smooth and reliable operations. Additionally, this initiative has resulted in monetary savings of approximately INR 30 lakh per disposal and refilling cycle.

Ajit Gugale, President, Operations, ZF Steering Gear (India) Ltd, states, "We are extremely pleased with our long-standing partnership with Blaser Swisslube and Proserv Tools. Our 12-year collaboration is built on trust and a strong commitment from both sides to deliver the highest standards of safety and environmental responsibility to the industry."

"Through teamwork, unwavering customer trust, and a mutual dedication to excellence, we not only achieve exceptional outcomes but consistently surpass expectations. This has been our approach at ZF Steering Gear (India) Ltd, and we are eager to continue our partnership," notes Prashant Godha, Sales Director, Automotive, Blaser Swisslube Solutions Pvt Ltd. **SD**

Blaser Swisslube Solutions Pvt Ltd
www.blaser.com
Hall & Stall: 7/A110

We help you win – now and in the future.

Decades of machining experience have taught us there are complex correlations between chemistry and mechanics. Profit from our knowledge to optimize your processes, keep them stable and quickly resolve issues.

Meet us at our booth A110 in hall 7. It's worth it.



SPHOORTI
Precision Assured

TOOL DISCS & TOOL HOLDERS
FOR CNC TURNING CENTERS & TURN MILL CENTERS

Sphoorti Machine Tools Pvt. Ltd.
Bangalore, INDIA



SLOTTED DISC & TOOL HOLDERS



VDI RADIAL DISC & TOOL HOLDERS

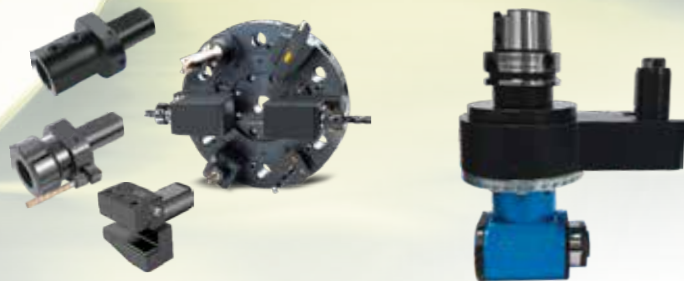

VDI AXIAL DISC & TOOL HOLDERS

ANGULAR MILLING HEAD



BMT DISC & TOOL HOLDERS



BMT-PSC (CAPTO-Compatible) TOOL DISC & TOOL HOLDERS



VDI AXIAL & RADIAL-PSC (CAPTO-Compatible) TOOL DISC & TOOL HOLDERS

Sphoorti Machine Tools Pvt. Ltd.,
18, Plot No. 467 - 469, 12th Cross, 4th Phase,
Peenya Industrial Area, Bangalore - 560 058, INDIA,
Ph : +91 80 4127 2768, +91 80 4117 1589
Email : info@sphoorti.com
Website : www.sphoorti.com

VISIT US AT HALL-4, STALL A-134
IMTEX 2025 Tooltech 2025 DIGITAL
23-29 JAN'24, BIEC, BANGALORE

INTERNATIONAL PRESENCE - VDW

Strengthening Indo-German Collaboration

As in previous years, AHK India is organizing a joint German participation on the initiative of German Machine Tool Builders' Association (VDW). This traditionally includes state participations from Baden-Württemberg and Bavaria. As part of this initiative, a total of 57 German companies are showcasing their offerings at IMTEX 2025 & Tooltech 2025. Numerous other companies, particularly larger ones, are represented independently outside of the joint participation through their own exhibition stands via their Indian subsidiaries. These companies have registered directly with IMTMA.

Indo-German Machine Tool Trade

India has been an important and large market for the German machine tool industry for a long time, says Kuhnmüch. "We are convinced that the Indian market will become even more important for us. The Indian economy grows much more stronger than most other countries," he adds. In 2023, exports of German machine tools to India amounted to € 250 million. This represents an increase of 28 percent compared to the previous year. In the first nine months of 2024, however, exports increased again by a remarkable 49 percent just over € 224 million. A wide range of machine types was sold in 2023, including machining



Source: VDW

» The German companies are aligning their technologies and machines at IMTEX 2025 with the specific needs of the Indian market and industry. Indian trade visitors are encouraged to engage with the German exhibitors and explore opportunities for cooperation and business collaboration.«

Klaus-Peter Kuhnmüch
Manager
General Affairs
German Machine Tool Builders' Association (VDW)

centers, grinding machines, honing machines, gear cutting machines, eroding machines, laser machines, turning machines and centers, presses, milling machines and others, he shares. SD

German Machine Tool Builders' Association (VDW)
www.vdw.de
Hall & Stall: 2B/C-102

Today's Engagement

Remembering Shailesh R. Sheth - A Memorial Lecture by Jamshyd N Godrej
Date: Friday, January, 24, 2025
Time: 11.00 AM - 12.30 AM
Venue: Gulmohar Hall, Conference Centre

AceMicromatic Group - Mitsubishi 1000th CNC Controller Supply to AMG Felicitation by Mitsubishi Team
Date: Friday, January, 24, 2025
Time: 11:30 AM - 12:00 PM
Venue: Hall & Stall: 5/B-109
Product Model: 540 G with Mitsubishi Control

AceMicromatic Group - Launch of Customer Portal & Customer Operator Knowledge Centre
Date: Friday, January, 24, 2025
Time: 10:30 AM - 11:00 AM
Venue: Hall & Stall: 5/B-109

PALMARY GROUP
For Sale

CENTERLESS



CYLINDRICAL



VERTICAL

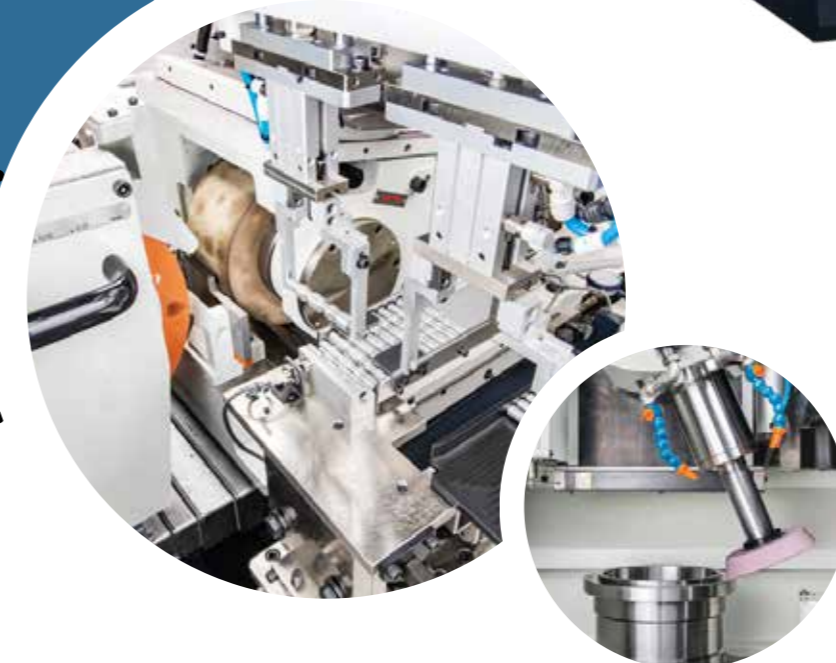

SPECIAL FEATURES

- Compound Grinding Solutions
- High Precision and Quality
- Seamless Automation
- Eco-friendly Design
- User-friendly with Intuitive Graphic Interface

Call for details
+886-4-24929799

For More Information
palmarty@grinding.com.tw

Visit Us
www.palmarty.com



PROCESS FLUID SOLUTIONS

Gaining Strength Through Sustainability



Quaker Houghton Team at its company booth at IMTEX 2025.

Quaker Houghton India
www.quakerhoughton.com
Hall & Stall: 5/A-129



» IMTEX 2025 marks the 22nd edition of this premier event, and Quaker Houghton is eager to participate. The event provides unparalleled opportunities for live demonstrations, knowledge sharing, and networking.«

Tridib Majumder
Managing Director
Quaker Houghton India

“IMTEX 2025 marks the 22nd edition of this premier event, and Quaker Houghton India is eager to participate,” shares Tridib Majumder, Managing Director, Quaker Houghton India. As a global leader in process fluid solutions, Quaker Houghton aims to leverage this opportunity to showcase its cutting-edge innovations and emphasize its global market presence.

A Platform for Collaboration

IMTEX serves as a unique platform for organizations to engage with manufacturers, demonstrate live technologies, and exchange knowledge. Majumder emphasizes, “The event provides unparalleled opportunities for live demonstrations, knowledge sharing, and networking.” With strong partnerships with leading machine tool builders worldwide, Quaker Houghton looks forward to connecting with these

partners and existing and potential customers under one roof.

Innovations in Fluid Intelligence

Quaker Houghton is set to highlight its QH FLUID INTELLIGENCE™ platform at IMTEX 2025. This advanced system integrates cutting-edge hardware and software to optimize fluid performance. “QH FLUID INTELLIGENCE™ provides real-time monitoring and control of fluid performance and cost, delivering fast, accurate, and actionable insights,” explains Majumder.

The platform includes:

- **QH FLUIDMONITOR™:** Automatic real-time measurement of key fluid and process parameters using proprietary sensor technology.
- **QH FLUIDCONTROL™:** Integration of sensors and control equipment for precise measurement and physical control.

- **QH FLUIDTREND™:** User-friendly software offering real-time data and analytics for better predictability of outcomes.

These solutions reduce manual sampling and analysis and enable manufacturers to improve fluid management processes, reduce costs, and enhance productivity.

Driving Sustainability in Manufacturing

Quaker Houghton’s sustainability portfolio demonstrates its commitment to driving long-term economic and environmental value.

Key innovations include:

- **QH CUTMAX® E Series:** Mineral oil-free cutting fluids made from renewable materials or re-refined oils.
- **QH EXOMAX™:** Low-temperature cleaners that enhance safety and efficiency.

- **HOCUT® Series:** Fluids that extend sump life and reduce waste.

“Our solutions help drive business performance while supporting improvements to human health, safety, and social outcomes,” the Managing Director states.

Focus on the Indian Market

Quaker Houghton sees India as a key growth region, with plans to expand its operations. “India is one of the markets where we will deploy resources and assets to achieve growth,” shares Majumder. With a state-of-the-art plant in Dahej, Gujarat, and plans for a new facility in eastern India, the company is well-positioned to meet rising demands. **SD**



Complete Automation Solution for Machine Tool Industry.

Delta presents its IoT-enabled automation products and solutions, delivering exceptional performance and reliability. Discover the cutting-edge NC5 CNC controller through live demonstrations that highlight its advanced features and superior capabilities.

Drive, Motion Control, Power Quality, HMI, PLC, CNC, Sensor, Meter, Field Device, Servo Press, Power Supply, Temperature Controller, Robot Solutions, Software like SCADA and Industrial EMS for complete smart manufacturing solutions.

Fastest Growing Automation Brand in India



BIEC, BENGALURU
23-29 Jan 2025

Hall No.5
Stall No.B103

automation@deltaww.com | www.deltaelectronicsindia.com



Would you like to be crowned a Productivity Champion ?

.... Share your success stories on PRODUCTIVITY | TECHNOLOGY | INNOVATION



IMTMA - ACE MICROMATIC
Productivity Championship
Awards 2025

Win Cash Awards upto

₹ 10,00,000

@

National Productivity Summit 2025
November 2025, Ahmedabad

AWARDS SPONSOR



No Entry Fee !

Multiple Entries are Welcome !

Rush your entries by 5 April 2025

Special streams Micro and Small Enterprises | Non-Automotive Industry | Automotive and Auto Component Industry

For more details, please log on to: www.productivity.imtma.in
or call Madan on: +91 7899437625 | E: madan@imtma.in

Organised by:



Indian Machine Tool Manufacturers' Association
www.imtma.in

CNC ROTARY TABLES

Pioneering Precision Rotary Tables

As the manufacturing industry undergoes rapid transformation, UCAM Pvt Ltd stands at the forefront, championing the critical role of Precision Rotary Tables in shaping advanced manufacturing processes. With the theme 'Advancing Manufacturing: Precision Rotary Tables for the Future', UCAM unveils its state-of-the-art CNC Rotary Tables at IMTEX 2025. UCAM Rotary Tables are engineered to seamlessly integrate with

cutting-edge production systems, empowering manufacturers to build smart factories equipped for the future. Designed for smooth workflows and exceptional precision, these rotary tables are indispensable for enhancing efficiency and productivity in next-generation manufacturing environments.

UCAM's Rotary Tables are celebrated for delivering unmatched precision, accuracy, and reliability, meeting the rigorous demands of these sectors. Engineered to achieve ultra-high precision, they set new benchmarks in performance, consistently exceeding customer expectations and solidifying UCAM's leadership in the precision rotary table market.

UCAM Pvt Ltd
www.ucamind.com
Hall & Stall: 1/A-102



Empowering Manufacturers

Beyond technical excellence, UCAM Rotary Tables are transformative tools that redefine operational efficiency. They enable CNC machines to create intricate parts with complex geometries while streamlining setups with enhanced accuracy. These versatile systems empower manufacturers to perform even the most complex tasks with unparalleled precision and efficiency, reinforcing UCAM's pivotal role in driving industrial progress and achieving superior production outcomes. **SD**

Small CNC Horizontal Special Machine
SMH series
A Modular CNC Machine Tool
Dual Spindle Machine
www.shengyumc.com.tw
SHENG YU PRECISION MACHINE CO., LTD.
Tel: 886-4-24923577 Fax: 886-4-24923977
b3734@ms16.hinet.net
No 97, Renmei Rd., Daili Dist., Taichung City 412, Taiwan

UNSTOPPABLE GRIT

WHAT HAPPENS WHEN WORLD-CLASS TOOL MAKING KNOWLEDGE PAIRS WITH WALTER TOOL GRINDERS?

Answer: your tool grinding capability becomes unstoppable. See all of the incredible WALTER technology at the UNITED GRINDING India booth!

- **WALTER HELICHECK PLUS:** multi-faceted tool measurement
- **WALTER HELITRONIC POWER 400:** original and innovative
- **WALTER HELITRONIC POWER 400 DIAMOND:** the original grinding/eroding 2-in-1
- **WALTER HELITRONIC G200:** tool grinding (with automation) in under 25 sq ft
- **WALTER HELITRONIC MINI PLUS:** option-rich for high volume production
- **WALTER HELICHECK NANO:** micro and nano tool measuring

Hall 4,
Booth A 115



DRIVE
THE FUTURE OF
MANUFACTURING
TECHNOLOGY!



Concurrent Shows



8 - 11 May 2025, Bharat Mandapam (Pragati Maidan), New Delhi

BOOK YOUR STALL NOW



Indian Machine Tool
Manufacturers' Association

Powered by IMTMA, organizer of **IMTEX**

www.mbx.co.in

www.facteq.in

GUN DRILLING MACHINES

Nagel's Single-Axis Gun Drilling Machine

Nagel's Single-Axis Gun Drilling Machine with TBT Technology has options for one, two, or four spindles. The machine has a modular design to enhance production and improve quality. It is suited for round-the-clock production and are successfully running at major auto OEMs and other general engineering companies. It is suitable for insert type gun drills.



Nagel Special Machines Pvt Ltd
www.francisklein.in
Hall & Stall: 4/B-113

The machine features a rigid structure with high stiffness, precision linear motion (LM) guides and ball screws, high-power/high-frequency spindles, a high-pressure coolant system with a chiller unit, and machine controls through a PLC/CNC system. It also includes fault diagnostics and on-screen alarms. Optional features comprise component counter rotation, an AC servo spindle, a part handling mechanism, a tool monitoring system, a mist collector, a safety light curtain, safety relays, and Industry 4.0-enabled IoT capabilities.



Scan Digital Paper

SHOWDAILY™

PMT MACHINES LIMITED PUNE & HALOL IMTEX 2025



CNC Turning Center 5000 ABC

CNC Gear Hobbing

CNC Vertical Turning



CNC Cylindrical Grinding



CNC Internal Grinding



Surface Grinding



Automat

YOU ARE INVITED TO VISIT THE EXHIBITION
HALL NO - 2A STALL NO - B110

23-29 January, 2025 | BIEC - Bangalore



www.pmtmachines.com



TIMTOS

A Global Leading Smart Manufacturing & Machine Tool Expo

March 3-8, 2025 Taipei, Taiwan

Keynote



Mr. Akihiro Teramachi
Chairman and CEO, THK



Mr. Takashi Teramachi
President and COO, THK



Mr. Haw Chen
CEO, Techman Robot Inc.

March 4, 2025 (Tue) 10:00 -12:00

Location Room 101, TICC

Main Themes



AI & Robotics



Future Smart Manufacturing



Green Power & Sustainability



Nangang Exhibition Center, Hall 1 & Hall 2 • TWTC Hall 1

Organizers: TAITRA Taiwan External Trade Development Council

TAMI TAIWAN ASSOCIATION OF MACHINERY INDUSTRY

www.timtos.com.tw

REWARDS & RECOGNITION

IMTMA Best Design Award 2025

The prestigious IMTMA Best Design Award has been instituted to recognize and reward companies for their best indigenously designed and developed products showcased at IMTEX. This year, the following companies have received the accolade: Grind Master Machines Pvt Ltd for its Special Purpose Bearing Race Superfinishing Machine, Kennametal India Ltd for its Blank Profile Grinding Machine BPG15, and Sunita Engineering Corporation for its 5 Axis CNC Micro Milling Machine 5X-100.



Source: Magic Wand Media

IMTMA Export Performance Award in Memory of Shailesh R. Sheth

The IMTMA Export Performance Award is to recognize and reward member companies who have made significant achievement in exports of machine tools and related products. This year, the award has been conferred upon Pragati Automation Pvt Ltd and Indotech Industries India Pvt Ltd.



Source: Magic Wand Media

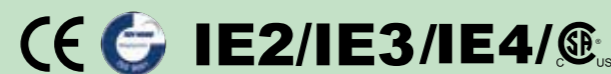

- ▶ **Machining**
Flooding | Circulating | Grinding | Chip Conveyor | Filtration
- ▶ **High Pressure Cooling**
Through Tool | Washing | Filtration
- ▶ **Oil Skimming**
Belt | Disc
- ▶ **Refrigeration / Temperature Control**
Printing | Packing | Welding | Mold Temperature
- ▶ **Media**
Water | Coolant | Chemicals | Oil | Ink | Varnish | Washing Solution
- ▶ **Pump with BLDC Motor**

Visit us at Hall 3A, Stall B111

High Speed High Precision CNC Rotary Tables

4th Axis redefined

- Integrated angle sensor
- Positioning accuracy: ±5"
- High clamping torque
- Universal mounting

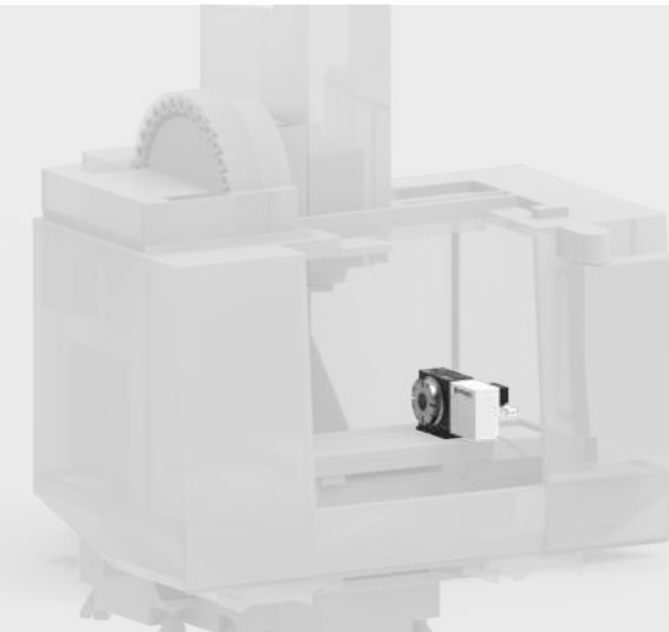
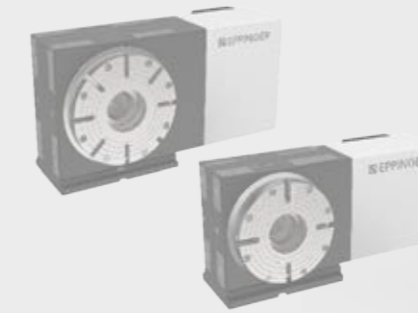

Your Partner For All Tool Holding Solutions

Up to fully automated tool change on lathes

- 1 QUICKLOCKBMT® tooling system
- 2 Tool holder HSK/SK/PSC
- 3 Automation for tool holder & work piece
- 4 Your work piece

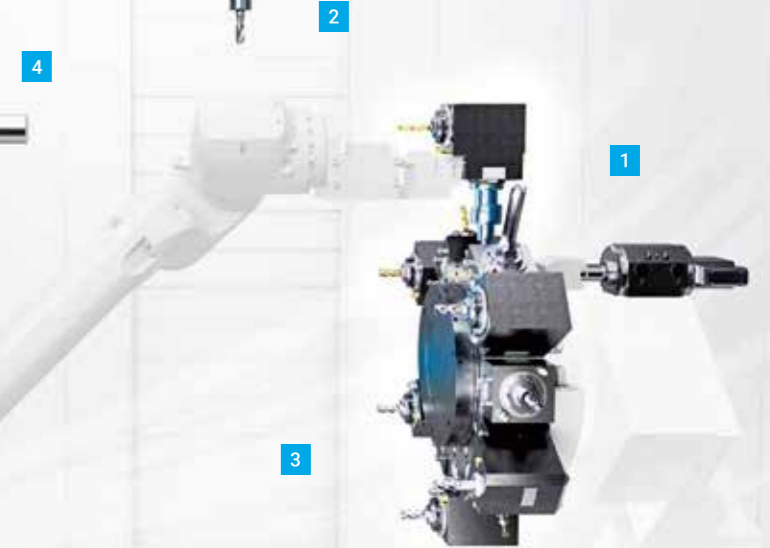

Precision Gear Units

For all machine tools

- 1 Tool disk / magazine
- 2 Tool changer
- 3 Material handling solutions

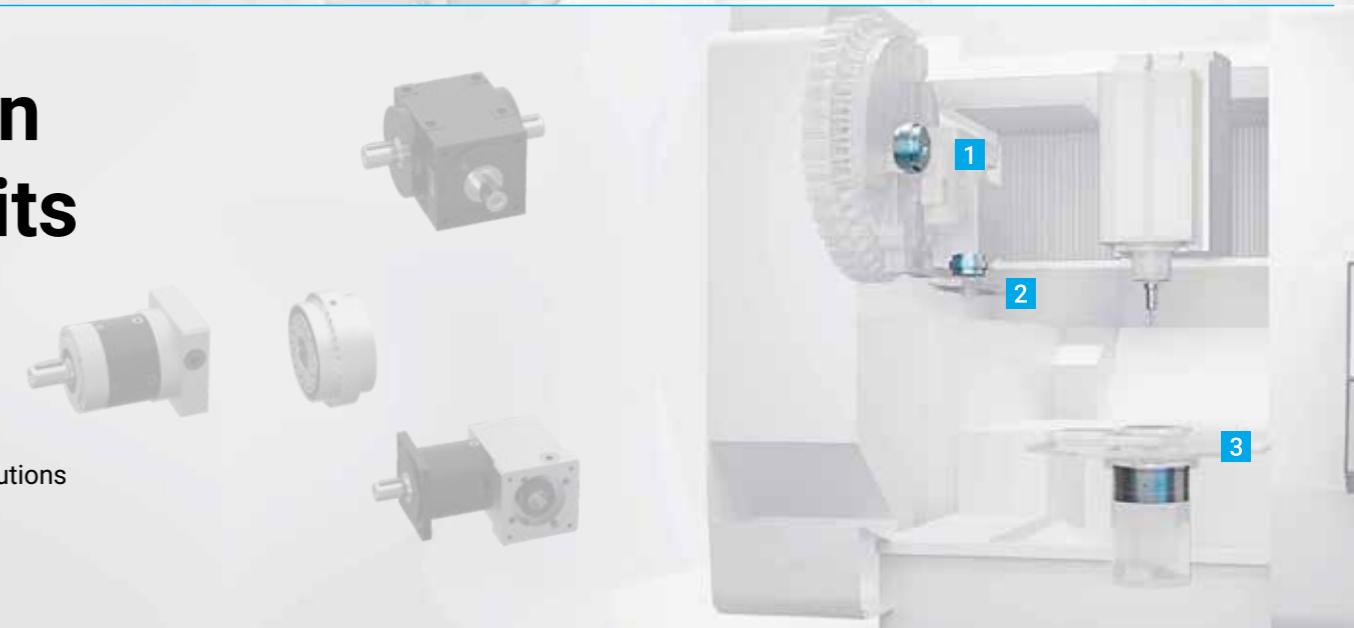

MACHINE LAUNCHES

AMG Launches Cutting-Edge Innovations

Taurus Riser Cutting Machine – TRCM-22

Taurus Riser Cutting machine TRCM-22 is suitable for the cutting of 'Riser and Runners' on aluminum alloy castings for automobile alloy wheels. The machine is designed to take alloy wheels from 10 in to 22 in diameter.

This machine is an intelligent system equipped with uniquely developed software and hardware, incorporating features that entirely 'de-skill' the operation process. A high-resolution camera at the

input chute captures the image of the incoming component and loads it into one of the four stations within the machine. The system then automatically configures all necessary settings, including the clamping mechanism, appropriate CNC program, axes travel, and cutting parameters.

All operations in the machine are controlled by a CNC System (FANUC) and high-torque Axes Servo Drives (FANUC) with absolute encoders. Component loading and unloading is with a custom-

made automation system. The machine bed is designed for a better chip disposal and a heavy-duty chip conveyor is optional.

APS 300 Power Skiving Machine

For decades, Ace Designers has been synonymous with innovation

in CNC Turning solutions, producing high-performance CNC lathes, Turn-Mills and Tooling solutions. At IMTEX 25, the brand is taking a significant leap forward by unveiling APS 300 Power Skiving Machine, a cutting-edge machine offering solutions for the gear manufacturing domain.



AceMicromatic Group
www.acemicromatic.net
Hall & Stall: 5/B-109



APS 300 Power Skiving Machine: Redefining Gear Manufacturing

Designed for internal gear manufacturing, this machine combines shaping and milling principles with high-speed machining advantages. It delivers precision, efficiency, and versatility, making it ideal for volume production.

- **Enhanced Capability:** Supports modules up to 3 mm with a swivelling cutter spindle angle of $\pm 30^\circ$ (manual setting), providing unparalleled flexibility for diverse applications.
- **Precision and Speed:** Combines shaping and milling principles with high-speed machining to deliver exceptional accuracy and reduced cycle times. **SD**

Source: Magic Wand Media



Rajamane & Hegde Services Pvt Ltd



Hybridspindle



More than only an alternative for indirect spindle solutions

The hybrid spindle is an impressive development - the combination of the master spindle motor and the spindle functionality results in a high-quality milling spindle.

The design includes all necessary spindle functionality, maximum speed up to 24,000 rpm and high accuracy because of direct driven technology. The Hybrid Spindle gives to machine builders the possibility to improve the performance of machines originally built with indirect spindle solution.

For more information, please ask for the spindle catalogue.

India's only authorised service partner for Weiss spindles



India's Largest Machine Tool Group with Global Foot Print

Visit us @  **Hall No: 05 | Stall No: B109**

**TRANSFORMING
ACCELERATING**

**MANUFACTURING
INNOVATION**

**40+ Exhibits
across modernising
domains**

**25,000+ sqft
Display area**

All You Need In Machining

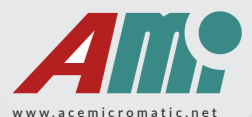



TOWN OF TECHNOLOGY

VISIT US AT HALL 5

